

Tensioner for foundation tape

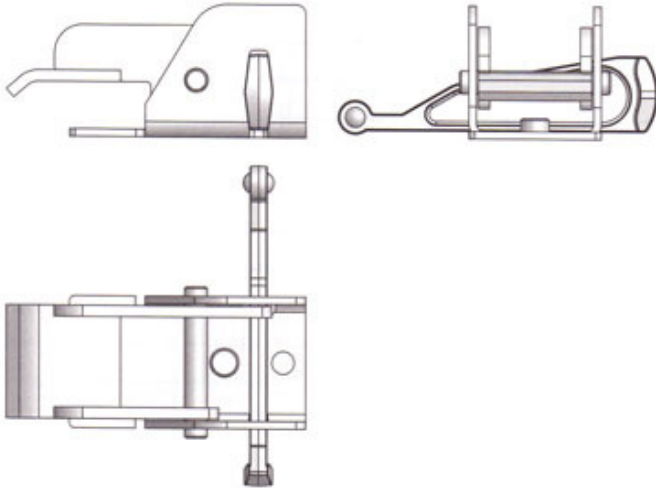

galvanized; to connect the foundation tape to MevaLite panels; it serves as bottom tie when panels are assembled in horizontal position. Two (2) tensioners are required per tying position.

Ref. No.	Dimensions	Weight
29-307-85	—	3.7 lb

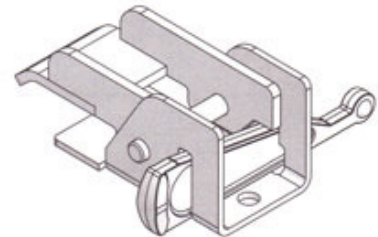

Foundation tape

galvanized; hole spacing 2" (50 mm); hole diameter 5/8" (16 mm); length 164' (50 m); adm. tension force 2.2 kips (10.0 KN); to be cut at hole center. Together with the appropriate tensioner it serves as bottom tie when panels are assembled in horizontal position.

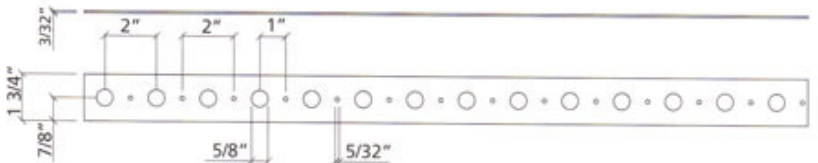

Ref.-No.	Dimensions	Weight
29-307-50	—	44.1 lb



Plug D27/30

to close unused tie holes

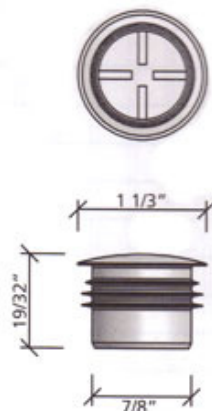

Ref.-No.	Dimensions	Weight
29-902-64	—	0.01 lb

